

The Bean–Livingston barrier at a superconductor/magnet interface

This article has been downloaded from IOPscience. Please scroll down to see the full text article.

2005 J. Phys.: Condens. Matter 17 L93

(<http://iopscience.iop.org/0953-8984/17/10/L02>)

View [the table of contents for this issue](#), or go to the [journal homepage](#) for more

Download details:

IP Address: 129.252.86.83

The article was downloaded on 27/05/2010 at 20:25

Please note that [terms and conditions apply](#).

LETTER TO THE EDITOR

The Bean–Livingston barrier at a superconductor/magnet interface*

Y A Genenko, H Rauh¹ and S V Yampolskii²

Institut für Materialwissenschaft, Technische Universität Darmstadt, 64287 Darmstadt, Germany

E-mail: hera@tgm.tu-darmstadt.de

Received 27 October 2004

Published 25 February 2005

Online at stacks.iop.org/JPhysCM/17/L93**Abstract**

The Bean–Livingston barrier at the interface of type-II superconductor/soft-magnet heterostructures is studied on the basis of the classical London approach. This shows a characteristic dependence on the geometry of the particular structure and its interface as well as on the relative permeability of the involved magnetic constituent. The modification of the barrier by the presence of the magnet can be significant, as is demonstrated for a cylindrical superconducting filament covered with a coaxial magnetic sheath. Using typical values of the relative permeability, the critical field of first penetration of magnetic flux is predicted to be strongly enhanced, whereas the variation of the average critical current density with the external field is strongly depressed, in accord with the observations of recent experiments.

1. Introduction

Heterostructures on the macro- or nano-scale involving type-II superconductor and ferromagnet elements show great potential for improving superconductor properties such as critical currents and critical fields, and therefore have been extensively studied both experimentally and theoretically during the past few years [1–27]. If hard magnets are used, the interaction of the magnetic vortices of the superconductor with the magnetic moments of the ferromagnet may lead to an enhancement of the pinning of the vortices [3–6] or to an increase of the critical fields [7, 15]. Soft magnets, on the other hand, aid to amend superconductor performance by shielding the transport current self-induced magnetic field as well as the externally imposed magnetic field [18–20, 28, 29]. Superconductors encompassed with such materials exhibit enlarged critical currents through wide ranges of the strength of an applied field, when in the

* This letter is dedicated to Professor A M Stoneham FRS on the occasion of his 65th birthday.

¹ Author to whom any correspondence should be addressed.

² On leave from: Donetsk Institute for Physics and Technology, National Academy of Sciences of Ukraine, 83114 Donetsk, Ukraine.

critical state [22–26], and even overcritical currents, when in the Meissner state [27]. The latter state persists until the shielding and/or transport currents, which push magnetic vortices into the superconductor bulk, overcome the Bean–Livingston barrier against entry of magnetic flux [30]; an impediment created by the (positive) Gibbs free energy of the vortices themselves. This suggests the surmise that, due to the induced magnetization, the presence of a soft magnet may alter the characteristics of nucleation of a vortex at the superconductor/magnet interface as compared to nucleation at the surface of a superconductor facing vacuum, the phenomenon analysed hitherto [30–35].

Any theoretical study of the Bean–Livingston barrier at the interface of a type-II superconductor/soft-magnet heterostructure, discerned by the observable critical field of first penetration of magnetic flux and the observable average critical current density of loss-free transport of electric charge interlinked with it, must resolve two cardinal points:

- (a) the dependence of these observables on the geometry of the particular structure and its interface;
- (b) the effect of the relative permeability of the involved magnetic constituent.

Here, we exemplify both traits for an infinite flat and, respectively, finite curved geometry of a type-II superconductor next to a soft-magnetic environment, adopting the classical London approach.

2. Theory

The magnetic induction \mathbf{B} in the superconductor region around a vortex obeys the London equation [36]

$$\mathbf{B} + \lambda^2 \nabla \times (\nabla \times \mathbf{B}) = \mathbf{Q}, \quad (1)$$

with the London penetration depth λ and the source \mathbf{Q} at position \mathbf{r} given by

$$\mathbf{Q}(\mathbf{r}) = \Phi_0 \int_{\text{vc}} d\mathbf{s} \delta(\mathbf{s} - \mathbf{r}), \quad (2)$$

where Φ_0 denotes the quantum of magnetic flux and δ means the Dirac delta function, the integration extending along the vortex core. The magnetic field \mathbf{H} in the magnet region and the magnetic induction \mathbf{B} in the entire space satisfy the Maxwell equations

$$\nabla \times \mathbf{H} = 0 \quad \text{and} \quad \nabla \cdot \mathbf{B} = 0. \quad (3)$$

To simplify later analysis, we postulate the relationship $\mathbf{B} = \mu\mu_0\mathbf{H}$ in the region confined to the magnet itself, assuming a (field-independent) relative permeability of the magnet, μ , apart from the permeability of free space, μ_0 . Furthermore, to avoid complications arising from the proximity effect, we invoke the presence of an insulating layer at the superconductor/magnet interface, of thickness much smaller than the London penetration depth (as observed, e.g., in MgB₂/Fe composites [26]) regarding, for mathematical convenience, this layer as infinitesimally thin. Boundary conditions then imply continuity of the tangential component of the magnetic field as well as of the normal component of the magnetic induction when the interface between the superconductor (S) and the magnet (M) is traversed:

$$B_{t,S} = \mu_0 H_{t,M} \quad \text{and} \quad B_{n,S} = \mu\mu_0 H_{n,M}. \quad (4)$$

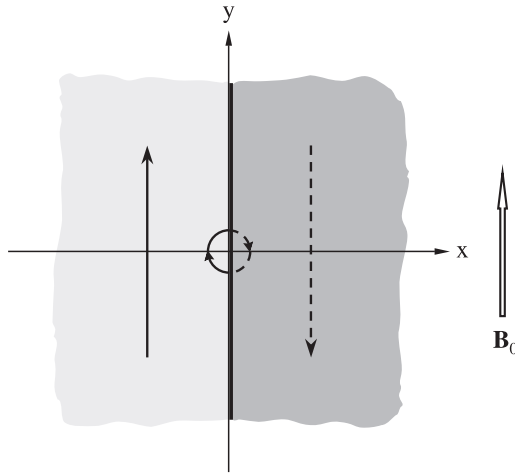

Figure 1. Schematic view of the semi-infinite superconductor (light shading) and the semi-infinite magnet (dark shading), their interface coinciding with the plane $x = 0$ of a Cartesian coordinate system x, y, z . The solid vertical line indicates the insulating layer between the superconductor and the magnet. A straight magnetic vortex parallel to the superconductor/magnet interface (arrowed full line) and its image (arrowed dashed line) as well as a magnetic vortex loop (arrowed full semicircle) and its image (arrowed dashed semicircle), all situated in the plane $z = 0$, are shown. The direction of the external field B_0 is marked.

2.1. Infinite flat geometry

The configuration addressed first is thought to consist of a superconductor extending across the infinite half-space $-\infty < x < 0$ and a soft magnet extending across the infinite half-space $0 < x < \infty$, their interface occupying the plane $x = 0$, with an externally imposed, homogeneous field B_0 pointing in the y -direction of a Cartesian coordinate system x, y, z , as shown in figure 1. For this usually discussed geometry of the Bean–Livingston barrier [30], the presence of the magnet does not affect the entry of a straight magnetic vortex parallel to the superconductor/magnet interface. Indeed, the vortex self-field here has a tangential component only, which vanishes at the interface owing to the vortex image field; the magnetization of the magnet thus is preserved, leaving the vortex field the same as that of a vortex near the flat surface of a semi-infinite superconductor facing vacuum. Nevertheless, the situation could change in the more realistic case of fluctuation penetration of a magnetic vortex loop (see figure 1), since the magnet then might experience additional magnetization, with a corresponding interaction energy contributing to the barrier at the superconductor/magnet interface.

The required solution of equations (1)–(4) for the magnetic induction B can be conveniently decomposed according to $B = B^m + b$, where B^m is the Meissner field induced by the external field in the absence of the magnetic vortex loop, with its only component

$$B_y^m(x) = B_0 \exp(x/\lambda), \quad (5)$$

and b is the asymptotically vanishing field of the loop itself. We represent the latter field and its source by two-dimensional Fourier integrals of the kind

$$f(r) = \frac{1}{(2\pi)^2} \int_{-\infty}^{\infty} dk_y \int_{-\infty}^{\infty} dk_z \tilde{f}^{(k_y, k_z)}(x) \exp[i(k_y y + k_z z)]. \quad (6)$$

For a vortex loop situated in the plane $z = 0$, the Fourier transforms of the Cartesian components of the vortex field inside the superconductor region are

$$\begin{aligned}\tilde{b}_{x,y}^{(k_y,k_z)}(x) &= \left[\tilde{b}_{x,y}^{(k_y,k_z)}(0) - \tilde{P}_{x,y}^{(k_y,k_z)}/2q\lambda^2 \right] \exp(qx) \\ &\quad + \frac{1}{2q\lambda^2} \int_0^a dx' \tilde{Q}_{x,y}^{(k_y,k_z)}(x') \exp(-q|x+x'|), \\ \tilde{b}_z^{(k_y,k_z)}(x) &= \tilde{b}_z^{(k_y,k_z)}(0) \exp(qx),\end{aligned}\quad (7)$$

where $q = (k^2 + 1/\lambda^2)^{1/2}$ with $k = (k_y^2 + k_z^2)^{1/2}$; the boundary values herein read

$$\begin{aligned}\tilde{b}_x^{(k_y,k_z)}(0) &= \mu \tilde{P}_x^{(k_y,k_z)}/(k + \mu q)\lambda^2, \\ \tilde{b}_{y,z}^{(k_y,k_z)}(0) &= ik_{y,z} \tilde{P}_x^{(k_y,k_z)}/k(k + \mu q)\lambda^2,\end{aligned}\quad (8)$$

with characteristic integrals of the type

$$\tilde{P}_{x,y}^{(k_y,k_z)} = \int_0^a dx' \tilde{Q}_{x,y}^{(k_y,k_z)}(x') \exp(-qx') \quad (9)$$

controlled by the shape of the loop and by the maximum distance between the loop and the interface, a . The vortex field inside the magnet region allows the representation $\mathbf{b} = -\mu\mu_0\nabla\psi$ through a scalar potential ψ , whose Fourier transform is given by

$$\tilde{\psi}^{(k_y,k_z)}(x) = \left[\tilde{P}_x^{(k_y,k_z)}/k(k + \mu q)\lambda^2 \right] \exp(-kx). \quad (10)$$

We note that, although the magnetic moment of the vortex loop, with its only component in the direction of the external field

$$m_y = \int_0^a dx' \tilde{Q}_y^{(0,0)}(x') [1 - \exp(-x'/\lambda)], \quad (11)$$

does not depend on μ , the self-energy of the loop, being determined by the field prevailing at the vortex core, could well be sensitive to the magnetic environment. Yet, adopting a semicircular shape of the loop with radius a , for which

$$\begin{aligned}\tilde{Q}_x^{(k_y,k_z)}(x) &= 2i\Phi_0 \sin[k_y(a^2 - x^2)^{1/2}] \\ \tilde{Q}_y^{(k_y,k_z)}(x) &= -2\Phi_0 [x/(a^2 - x^2)^{1/2}] \cos[k_y(a^2 - x^2)^{1/2}],\end{aligned}\quad (12)$$

we find, using equations (7)–(10) in the region outside the vortex core whose radial extent may be delineated by the coherence length of the superconductor bulk, $\xi \ll \lambda$, that the self-energy is represented by the dominant term proportional to the length of the loop,

$$F_{\text{fi}} \cong \left(\frac{\Phi_0^2}{4\pi\mu_0\lambda^2} \right) \pi a \ln\left(\frac{a}{\xi}\right), \quad (13)$$

apart from small corrections including the factor $1/\mu$ due to the contribution of the magnet; a result which restates that for a semi-infinite superconductor with a flat surface facing vacuum [33, 34]. Intuitively, the decaying tendency of the omitted corrections with increasing relative permeability here can be conceived in the following way: the requirement of continuity of the normal component of the magnetic induction across the superconductor/magnet interface on the one hand, and the definition of the total magnetic flux through its quantization in the superconductor on the other hand, ensure that the strength of the magnetic induction in the magnet region is typically $B \sim \Phi_0/\lambda^2$, whereas the strength of the magnetic field in the magnet region is typically $H \sim \Phi_0/\mu\mu_0\lambda^2$. This yields a contribution to the self-energy of the loop, proportional to the product of both quantities, which falls off as indicated above.

The Bean–Livingston barrier arises from a competition between attraction of the vortex loop to the superconductor/magnet interface, accounted for by equation (13), and repulsion

due to the Lorentz force exerted—by the Meissner current—on the loop. In the geometry of figure 1, this current flows perpendicular to the plane $z = 0$, and the work done by the external field during growth of the loop from radius $a \simeq \xi$ to radius $\xi \ll a \ll \lambda$ is proportional to the area finally covered by the loop,

$$\Delta W_{\text{fi}}(B_0) \simeq \frac{1}{2} \Phi_0 \pi a^2 j_z^{\text{m}}(B_0), \quad (14)$$

where

$$j_z^{\text{m}}(B_0) = B_0 / \mu_0 \lambda \quad (15)$$

means the density of the Meissner current at the flat superconductor/magnet interface. From equations (13) and (14), the Gibbs free energy of the loop, i.e. the thermodynamic function of relevance here, when $\xi \ll a \ll \lambda$, becomes

$$G_{\text{fi}}(B_0) \simeq \left(\frac{\Phi_0^2}{4\pi \mu_0 \lambda^2} \right) \pi a \ln \left(\frac{a}{\xi} \right) - \frac{1}{2} \Phi_0 \pi a^2 j_z^{\text{m}}(B_0), \quad (16)$$

identifying the interface barrier against entry of the loop as a function of the strength of the external field. Once, when B_0 is fixed, the radius of the growing loop has reached its critical size a_c defined by the condition $\partial G_{\text{fi}} / \partial a = 0$, further loop expansion becomes irreversible and vortex entry proceeds. Depending on the quality of the superconductor/magnet interface, this may happen at different values of the critical loop radius throughout the range (and even beyond) where equation (16) applies. Whilst for an ideal interface, with scale of roughness $\sigma < \xi$, vortex entry occurs at a distance $a_c \simeq \xi$, in the case of a real interface, with scale of roughness $\xi \leq \sigma \leq \lambda$, vortex entry occurs for $a_c = \sigma$. Equation (16) in conjunction with equation (15) thus yields for the critical field of first penetration of magnetic flux across the flat superconductor/magnet interface

$$B_{\text{p}}^0 = \left(\frac{\Phi_0}{4\pi \lambda \sigma} \right) \ln \left(\frac{\sigma}{\xi} \right); \quad (17)$$

a form which assumes values between $B_{\text{c}1}$ and B_{c} , the lower and, respectively, thermodynamic critical field [36], when σ varies between λ and ξ . Obviously, the interface barrier against entry of the loop, and therefore the critical field of first penetration of magnetic flux as well as the average critical current density deriving from it, are insensitive to the magnetic environment, since, in the infinite configuration of figure 1, the external field remains totally unshielded. However, in any finite superconductor/magnet heterostructure, with the range of its magnetic constituent extending below the distance to the sources of this field, a significant shielding effect may indeed occur.

2.2. Finite curved geometry

The configuration addressed next is thought to consist of a cylindrical superconducting filament of radius R , extended infinitely in the z -direction of a Cartesian coordinate system x, y, z and covered with a coaxial magnetic sheath of thickness d , the externally imposed, homogeneous field B_0 again being aligned parallel to the y -direction, as depicted in figure 2. Whereas the self-energy of an (almost) semicircular vortex loop of radius $a \ll \lambda, R$, located in the plane $z = 0$ and nucleated at the filament/magnet interface, duplicates the dominant term given by equation (13),

$$F_{\text{ci}} \simeq \left(\frac{\Phi_0^2}{4\pi \mu_0 \lambda^2} \right) \pi a \ln \left(\frac{a}{\xi} \right), \quad (18)$$

with corrections due to the effect of the magnetic sheath even smaller than those for the infinite configuration examined above [35, 37], the Meissner current, and hence the work done by the

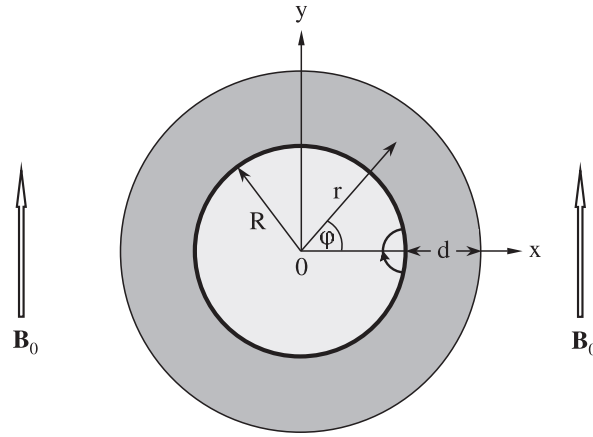

Figure 2. Cross-sectional view of the superconducting filament of radius R (light shading) and the coaxial magnetic sheath of thickness d (dark shading), their axes coinciding with the z -axis of a Cartesian coordinate system x, y, z . The solid ring indicates the insulating layer between the superconducting filament and the magnetic sheath. A magnetic vortex loop (arrowed semicircle, size not to scale!) situated in the plane $z = 0$ and nucleated at the filament/magnet interface is shown. The direction of the external field B_0 and the definition of cylindrical polar coordinates (r, φ, z) are marked.

external field during growth of the loop, as stated by equation (14), does change markedly when considering the finite magnetic environment. We therefore quote the Meissner solution of equation (1) expressed in cylindrical polar coordinates (r, φ, z) adapted to the filament: the radial and azimuthal components of the magnetic induction inside the superconductor region are [38]

$$\begin{aligned} B_r^m(r, \varphi) &= B_0 A_S [I_0(r/\lambda) - I_2(r/\lambda)] \sin \varphi, \\ B_\varphi^m(r, \varphi) &= B_0 A_S [I_0(r/\lambda) + I_2(r/\lambda)] \cos \varphi, \end{aligned} \quad (19)$$

with

$$A_S = 4\mu / \{[(\mu + 1)^2 - (\mu - 1)^2 R^2 / (R + d)^2] I_0(R/\lambda) + (\mu^2 - 1) [1 - R^2 / (R + d)^2] I_2(R/\lambda)\}, \quad (20)$$

where I_0 and I_2 denote modified Bessel functions of the first kind. Equations (19) in conjunction with Ampère's law yield for the density of the Meissner current flowing along the filament

$$j_z^m(r, \varphi) = 2j_z^m(B_0) A_S I_1(r/\lambda) \cos \varphi; \quad (21)$$

an expression which adopts its maximum absolute value on the circumference of the filament, $j_{\max}^m(B_0)$, at angles $\varphi = 0$ and π indicating the points of most probable nucleation of the vortex loop. Accordingly, the work done by the external field during growth of the loop from radius $a \approx \xi$ to radius $\xi \ll a \ll \lambda$ is

$$\Delta W_{ci}(B_0) \approx \frac{1}{2} \Phi_0 \pi a^2 j_{\max}^m(B_0), \quad (22)$$

where, in the practically important limit $R \gg \lambda$,

$$j_{\max}^m(B_0) \approx j_z^m(B_0) / \alpha \quad (23)$$

represents the density of the Meissner current at the curved filament/magnet interface, the parameter

$$\alpha = \frac{1}{4} [\mu + 1 - (\mu - 1) R^2 / (R + d)^2] \quad (24)$$

subsuming the combined shielding effect of the superconducting filament and the magnetic environment. Thus, from equations (18) and (23), the Gibbs free energy of the loop, say at the point $\varphi = 0$, when $\xi \ll a \ll \lambda$, becomes

$$G_{ci}(B_0) \cong \left(\frac{\Phi_0^2}{4\pi\mu_0\lambda^2} \right) \pi a \ln\left(\frac{a}{\xi}\right) - \frac{1}{2} \Phi_0 \pi a^2 j_{\max}^m(B_0). \quad (25)$$

Evidently, the interface barrier against entry of the loop, taken as a function of the strength of the external field, does prove sensitive to the presence of the magnet owing to appreciable shielding of this field in the finite configuration of figure 2. Again, referring to the condition $\partial G_{ci}/\partial a = 0$ applied to equation (25) in conjunction with equations (15), (17) and (23), we find for the critical field of first penetration of magnetic flux across the curved filament/magnet interface, if $R \gg \lambda$,

$$B_p \cong \alpha B_p^0, \quad (26)$$

revealing a substantial enhancement by the factor α as compared to the respective field of first penetration of magnetic flux across the flat superconductor/magnet interface for moderately high values of the relative permeability already, brought about by the shielding effect.

The flow of a transport current, of magnitude i_t , along the filament means that the Meissner current density, given by equation (21), is to be supplemented with the corresponding isotropic current density [39]

$$j_{z,t}(r) = (i_t/2\pi R\lambda) I_0(r/\lambda)/I_1(R/\lambda), \quad (27)$$

and hence the maximum current density $j_{\max}^m(B_0)$ entering equation (25) must be replaced by the maximum total current density expressed, if $R \gg \lambda$, by

$$j_{\text{tot}}(B_0) \cong j_{\max}^m(B_0) + i_t/2\pi R\lambda. \quad (28)$$

When a_c is fixed, the condition $\partial G_{ci}/\partial a = 0$ determines the average critical current density of loss-free transport along the filament, $j_c = i_t/\pi R^2$, as well. Resorting to equations (23), (25) and (28) in conjunction with equations (15) and (17), we get for $B_0 < B_p$, if $R \gg \lambda$,

$$j_c(B_0) \cong 2[B_p^0 - B_{\max}^m(B_0)]/\mu_0 R, \quad (29)$$

where

$$B_{\max}^m(B_0) \cong B_0/\alpha, \quad (30)$$

according to equations (19), reflects the maximum strength of the magnetic induction at the curved filament/magnet interface. The average critical current density thus is seen to fall off linearly with the strength of the external field, at a rate determined by the parameter α , i.e. by the shielding effect of both the superconducting filament and the magnetic environment, revealing a strong reduction of the field dependence for moderately high values of the relative permeability already, while the zero-field value of the average critical current density is conserved.

We comment that, if the filament were absent, and hence shielding confined to the magnetic sheath alone, the maximum strength of the magnetic induction at the curved inner surface of the sheath would be decreased. By formally letting $\lambda \rightarrow \infty$ for fixed R , equations (19) yield

$$B_{\max}^0(B_0) = B_0/\beta \quad (31)$$

with the parameter

$$\beta = \frac{1}{4\mu} [(\mu + 1)^2 - (\mu - 1)^2 R^2 / (R + d)^2], \quad (32)$$

duplicating an otherwise derived result [40]. Since $\beta > \alpha$ holds for any value of the geometrical and material characteristics involved, $B_{\max}^0(B_0) < B_{\max}^m(B_0)$ ensues throughout,

which confirms that the predicted enhancement of the critical field, disclosed by equation (26), like the concomitant attenuation of the external field, revealed by equation (30), cannot be exclusively ascribed to the shielding effect of the magnetic sheath, as argued in some previous attempts [21, 41–43].

To appraise the relevance of the above results, we take a MgB₂ filament with radius $R = 5.0 \times 10^{-4}$ m covered by an Fe sheath of thickness $d = 2.5 \times 10^{-4}$ m and relative permeability $\mu = 50$ [22–24], noting the practically interesting temperature of 32 K, at which the London penetration depth and the coherence length adopt the respective values $\lambda = 1.8 \times 10^{-7}$ m and $\xi = 6.5 \times 10^{-9}$ m [44]. If the scale of roughness σ , and hence the critical loop radius a_c , varies between the limits λ and ξ , the critical field of first penetration of magnetic flux across the curved filament/magnet interface, B_p , given by equation (26), is found to range between about 0.16 and 1.02 T (as compared to the range between about 0.01 and 0.07 T when the magnetic sheath were absent), and the average critical current density, $j_c(B_0)$, from equation (29), turns out to vary between about 6.84×10^7 and 4.42×10^8 A m⁻² at zero external field, its rate of change with the field, $\partial j_c / \partial B_0$, amounting to about -4.36×10^8 A m⁻² T⁻¹ (as opposed to about -6.37×10^9 A m⁻² T⁻¹ when the magnetic sheath were absent). These estimates are in accord with the observations of recent experiments [22–24]. We add that, considering the moderately large ratio λ/ξ of around 28, the low critical temperature of about 40 K and the just minor anisotropy of polycrystalline MgB₂ [44], thermally activated penetration of magnetic flux across the barrier, considered before [32, 33], here is insignificant.

3. Summary

In conclusion, we have studied the Bean–Livingston barrier at the interface of type-II superconductor/soft-magnet heterostructures and demonstrated a characteristic dependence on the geometry of the particular structure and its interface as well as on the relative permeability of the involved magnetic constituent. Thus, for the flat interface between a semi-infinite superconductor and a semi-infinite magnet, the external field remains totally unshielded, leaving the barrier essentially the same as that at the flat surface of a semi-infinite superconductor facing vacuum. However, in any superconductor/magnet heterostructure where substantial shielding of the external field occurs, the modification of the barrier by the presence of the magnet can be significant, as has been demonstrated for the example of a cylindrical superconducting filament covered with a coaxial magnetic sheath. In this finite geometry, with its curved superconductor/magnet interface, using typical values of the relative permeability, we predict that the critical field of first penetration of magnetic flux is strongly enhanced and, concomitantly, that the variation of the average critical current density of loss-free transport of electric charge with the external field is strongly depressed; the zero-field critical current density value, however, is retained, since the transport current self-induced magnetic field remains unshielded in this geometry. Owing to the expulsion of magnetic flux out of the filament, the attenuation of the external field, and hence the field dependence of the average critical current density, cannot be ascribed to the shielding effect of the magnetic environment alone.

Stimulating discussions with S X Dou, H C Freyhardt, A Gurevich, J Horvat, H Jarzina, C Jooss, A V Pan, F M Peeters, M D Sumpston and V M Vinokur are gratefully acknowledged. This work was supported by the VORTEX Programme of the European Science Foundation (ESF) and by a research grant from the German Research Foundation (DFG).

References

- [1] Martín J I, Vélez M, Nogués J and Schuller I K 1997 *Phys. Rev. Lett.* **79** 1929
- [2] Martín J I, Vélez M, Hoffmann A, Schuller I K and Vicent J L 1999 *Phys. Rev. Lett.* **83** 1022
- [3] Van Bael M J, Temst K, Moshchalkov V V and Bruynseraede Y 1999 *Phys. Rev. B* **59** 14674
- [4] Van Bael M J, Bekaert J, Temst K, Van Look L, Moshchalkov V V, Bruynseraede Y, Howells G D, Grigorenko A N, Bending S J and Borghs G 2001 *Phys. Rev. Lett.* **86** 155
- [5] Lange M, Van Bael M J, Moshchalkov V V and Bruynseraede Y 2002 *Appl. Phys. Lett.* **81** 322
- [6] Van Bael M J, Raedts S, Temst K, Swerts J, Moshchalkov V V and Bruynseraede Y 2002 *J. Appl. Phys.* **92** 4531
- [7] Lange M, Van Bael M J, Bruynseraede Y and Moshchalkov V V 2003 *Phys. Rev. Lett.* **90** 197006
- [8] Marmorkos I K, Matulis A and Peeters F M 1996 *Phys. Rev. B* **53** 2677
- [9] Lyuksyutov I F and Pokrovsky V L 1998 *Phys. Rev. Lett.* **81** 2344
- [10] Bulaevskii L N, Chudnovsky E M and Maley M P 2000 *Appl. Phys. Lett.* **76** 2594
- [11] Erdin S, Lyuksyutov I F, Pokrovsky V L and Vinokur V M 2002 *Phys. Rev. Lett.* **88** 017001
- [12] Erdin S, Kayali A F, Lyuksyutov I F and Pokrovsky V L 2002 *Phys. Rev. B* **66** 014414
- [13] Helseth L E, Goa P E, Hauglin H, Baziljevich M and Johansen T H 2002 *Phys. Rev. B* **65** 132514
- [14] Milošević M V, Yampolskii S V and Peeters F M 2002 *Phys. Rev. B* **66** 174519
- [15] Milošević M V and Peeters F M 2003 *Phys. Rev. B* **68** 024509
- [16] Laiho R, Lähderanta E, Sonin E B and Traito K B 2003 *Phys. Rev. B* **67** 144522
- [17] Erdin S 2004 *Phys. Rev. B* **69** 214521
- [18] Genenko Y A, Usoskin A and Freyhardt H C 1999 *Phys. Rev. Lett.* **83** 3045
- [19] Genenko Y A, Snezhko A and Freyhardt H C 2000 *Phys. Rev. B* **62** 3453
- [20] Majoros M, Glowacki B A and Campbell A M 2000 *Physica C* **334** 129
- [21] Majoros M, Glowacki B A and Campbell A M 2000 *Physica C* **338** 251
- [22] Soltanian S, Wang X L, Kusevic I, Babic E, Li A H, Qin M J, Horvat J, Liu H K, Collings E W, Lee E, Sumption M D and Dou S X 2001 *Physica C* **361** 84
- [23] Horvat J, Wang X L, Soltanian S and Dou S X 2002 *Appl. Phys. Lett.* **80** 829
- [24] Pan A V, Zhou S, Liu H K and Dou S X 2003 *Supercond. Sci. Technol.* **16** L33
- [25] Pan A V, Zhou S and Dou S X 2004 *Supercond. Sci. Technol.* **17** S410
- [26] Pan A V and Dou S X 2004 *J. Appl. Phys.* **96** 1146
- [27] Jarzina H, Jooss C and Freyhardt H C 2002 *J. Appl. Phys.* **91** 3775
- [28] Genenko Y A, Rauh H and Snezhko A 2001 *Supercond. Sci. Technol.* **14** 699
- [29] Genenko Y A, Rauh H and Snezhko A 2002 *Physica C* **372–376** 1389
- [30] Bean C P and Livingston J D 1964 *Phys. Rev. Lett.* **12** 14
- [31] Galajko V P 1966 *Zh. Exp. Teor. Fiz.* **50** 1322
- [32] Petukhov B V and Chechetkin V R 1974 *Zh. Exp. Teor. Fiz.* **65** 1653
- [33] Koshelev A E 1992 *Physica C* **191** 219
- [34] Samokhvalov A V 1995 *Zh. Exp. Teor. Fiz.* **108** 1091
- [35] Genenko Y A, Snezhko A, Troche P, Hoffmann J and Freyhardt H C 1998 *Phys. Rev. B* **57** 1164
- [36] De Gennes P G 1994 *Superconductivity of Metals and Alloys* (New York: Addison-Wesley)
- [37] Genenko Y A and Snezhko A 2002 *J. Appl. Phys.* **92** 357
- [38] Genenko Y A, Yampolskii S V and Pan A V 2004 *Appl. Phys. Lett.* **84** 3921
- [39] Schafroth M R 1960 *Solid State Physics* vol 10, ed F Seitz and D Turnbull (New York: Academic) p 336
- [40] Batygin V V and Toptygin I N 1978 *Problems in Electrodynamics* (London: Academic)
- [41] Sumption M D, Lee E, Collings E W, Wang X L and Dou S X 2001 *Adv. Cryog. Eng. Mater.* **48** 824
- [42] Sumption M D, Collings E W, Lee E, Wang X L, Soltanian S and Dou S X 2002 *Physica C* **378–381** 894
- [43] Sumption M D, Collings E W, Lee E, Wang X L, Soltanian S, Dou S X and Tomsic M 2002 *Physica C* **382** 98
- [44] Canfield P C, Bud'ko S L and Finnemore D K 2003 *Physica C* **385** 1